

EXTERIOR USL-SB1B

Slim Shoebox



PROJECT		TYPE		DATE	
---------	--	------	--	------	--



OVERVIEW

The US Luminaire slim shoebox series is widely used on urban roads, industrial areas, residential areas, sidewalks, parking lots, schools, and gardens. Its rugged design and highly efficient lighting make it a great choice in all climates. The newest revision features a universal mount to reduce inventory needs.

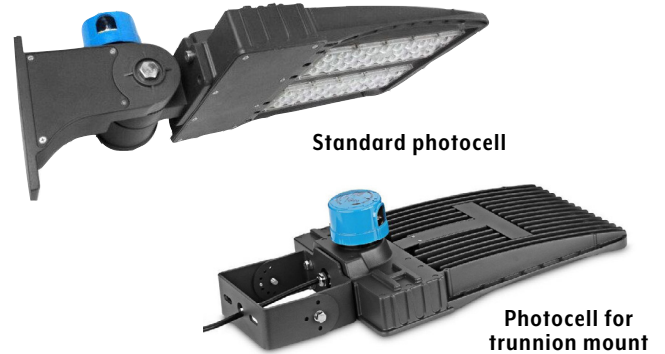

FEATURES

- IP65
- Updated mounting and photocell location
- High efficiency LED driver
- Die cast aluminum design provides better cooling
- Photocell sensor optional

ORDERING INFORMATION

EXAMPLE PN: USL-SB1B-150W-LV-40K-T3-10V-D

USL-SB1B	POWER	VOLTAGE	CCT	DISTRIBUTION*	DIMMING	FINISH*
	60W 60 WATTS	LV 120-277V	40K 4000K	T2 TYPE II	10V 0-10V	D DARK BRONZE
	100W 100 WATTS	HV 200-480V	50K 5000K	T3 TYPE III		W WHITE
	150W 150 WATTS			T4 TYPE IV		B BLACK
	200W 200 WATTS			T5 TYPE V		S SILVER
	300W 300 WATTS					

*Note: Type 3 is standard. Dark bronze is standard

ACCESSORIES

USL-SB1B-ACC	ACCESSORY	FINISH*
A	Arm mount	D Dark Bronze
S	Slip fitter	W White
T	Trunnion	B Black
U	Universal pole mount	S Silver
P	Photocell (2-part assembly)	

*Note: Dark bronze is standard.

ACCESSORIES

USL-SB1B-ACC	ACCESSORY
MS	Motion sensor
SC	Shorting cap



EXTERIOR USL-SB1B

Slim Shoebox



SPECIFICATIONS

MODEL	OPERATION VOLTAGE	OPERATING TEMPERATURE	RATED LIFESPAN	CCT	CRI	EFFICACY
USL-SB1B	120-277V AC 200-480V AC	-22°F – 113°F -30°C – 45°C	50,000 HOURS	4000K 5000K	70+	130-145 lm/W

MODEL	POWER (W)	LUMENS (lm) ±10%	EFFICACY (lm/W)	REPLACES MH
USL-SB1B-60W	60	8,700	145	150-250W
USL-SB1B-100W	100	13,000	130	250-400W
USL-SB1B-150W	150	21,000	140	300-500W
USL-SB1B-200W	200	25,000	135	400-600W
USL-SB1B-300W	300	39,000	130	500-1000W

DIMENSIONS

MODEL	L1 FIXTURE LENGTH	L2 TOTAL LENGTH	W WIDTH	H1 ARM MOUNT HEIGHT	H2 TOTAL HEIGHT	WEIGHT
USL-SB1B-60W	16.6 in 420 mm	23.8 in 604 mm	11.1 in 283 mm	6.3 in 160 mm	8.9 in 225 mm	9.9 lb 4.5 kg
USL-SB1B-100W						9.9 lb 4.5 kg
USL-SB1B-150W	17 in 431 mm	24 in 606 mm				13.2 lb 6 kg
USL-SB1B-200W						16.6 lb 7.5 kg
USL-SB1B-300W	18 in 456 mm	25.2 in 640 mm				15.9 in 403 mm

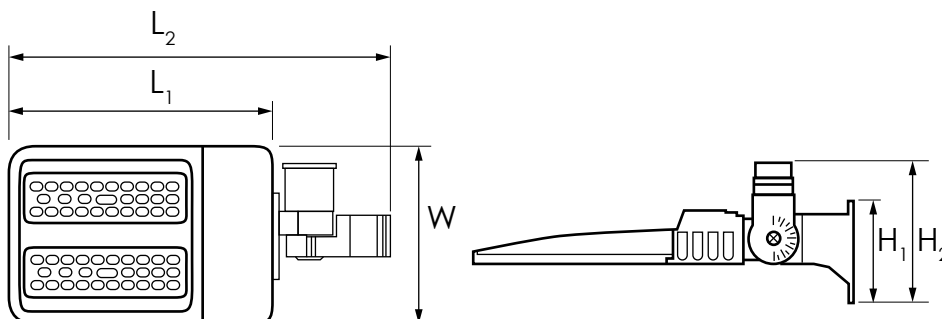

MOUNTING ACCESSORY DIMENSIONS

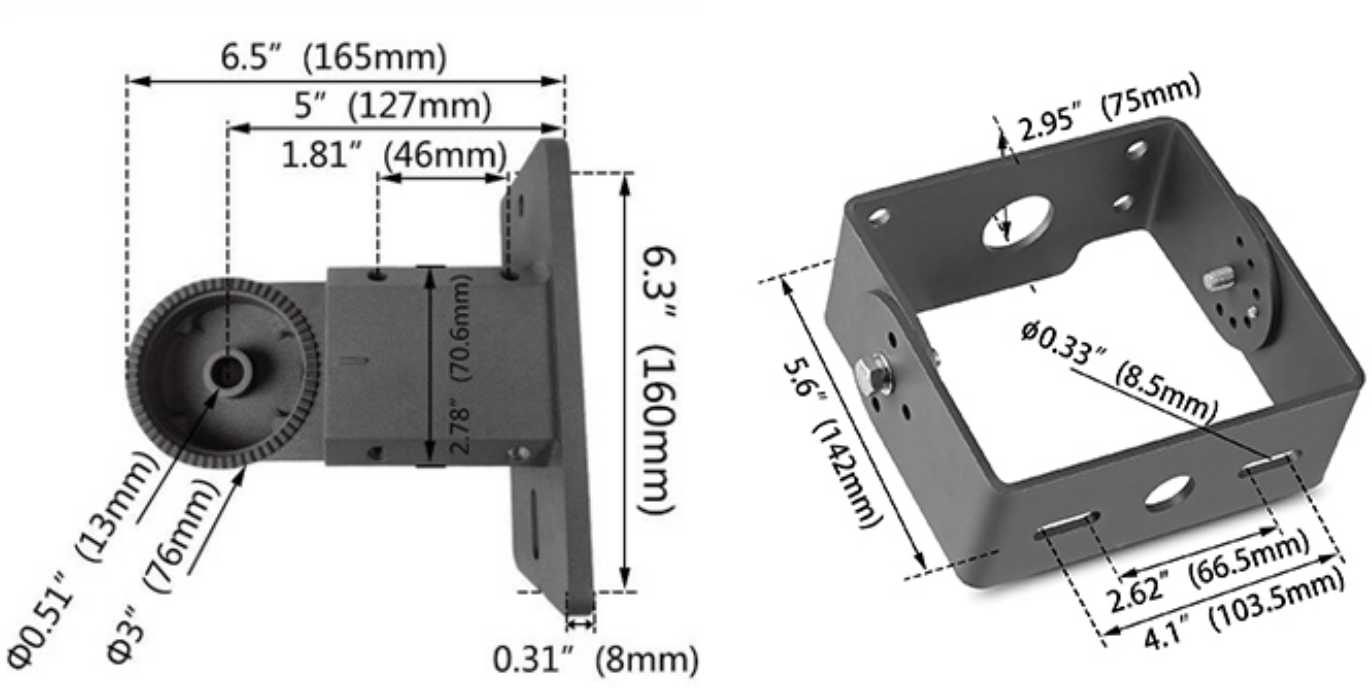
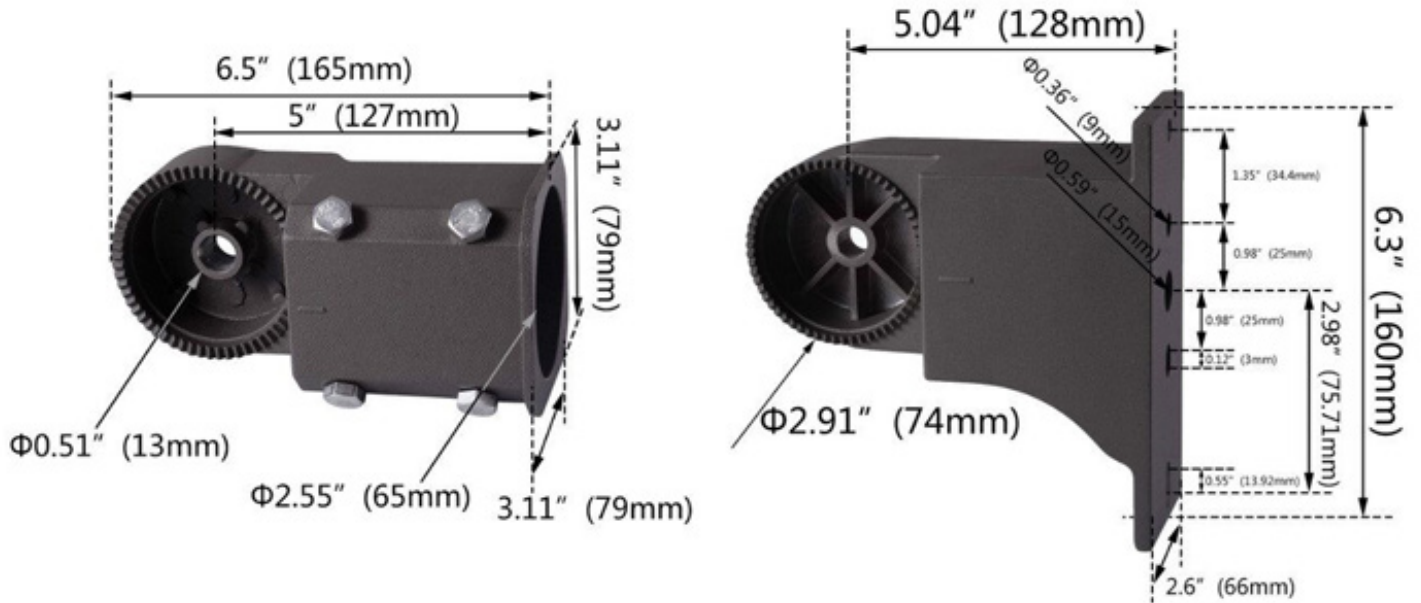

INSTALLING MOUNTING ACCESSORIES

